

UD TRUCKS

GW470

Leaf Suspension

GVM 26,000kg* GCM 70,000kg B-Double Rated**

Specifications



ENGINE

Make and model:	NISSAN DIESEL GE13TD
4 cycle, direct injection, overhead cam 4 valve, water cooled, in-line diesel engine with variable nozzle turbocharger and intercooler	
Number of cylinders:	6 cylinders
Bore x stroke:	136 mm x 150 mm
Total piston displacement:	13,074 cc
Max. output (ECE Net):	340 kw (460 PS) at 1,800 rpm
Max. torque (ECE Net):	2,255 N.m (230 kgm) at 1,200 rpm
Max. governed speed:	2,000 rpm
Compression ratio:	17.5 : 1
Auxiliary brake:	Exhaust + Engine compression brake (EE brake)
Lubrication System:	
Forced feed by gear pump, Flat tube type oil cooler, Full flow and by-pass oil filter with replaceable element, 42 litre capacity	
Air system:	
Water cooled reciprocating type, twin cylinder air compressor with oil mist separator and air dryer	
Cooling System:	
Forced feed by centrifugal water pump, Wax pellet type thermostats incorporated with a by-pass, Aluminium corrugate fin type radiator with reserve tank and Viscous coupling with 720mm dia 10 blade cooling fan	

FUEL AND INTAKE SYSTEM

Ultra high pressure unit injector fuel injection system
 Replaceable primary and secondary fuel filters
 400lt capacity aluminium fuel tank with lockable cap mounted on LHS
 Primary & Secondary dry paper element air filters
 High mounted LHS air intake

EXHAUST AND EMISSION CONTROL SYSTEM

Emission standard - ADR80/02 (JAPAN 05LT - Euro 5 emission levels)
 Primary - Selective catalytic reduction (SCR)
 55lt stainless steel AdBlue tank with lockable cap mounted on LHS
 Secondary - Electronic controlled selective cooled EGR
 LHS chassis mounted muffler/cat with horizontal exhaust discharge under truck

ELECTRICAL

24 volt, negative ground system
 2 x 12 volt 150 Ah batteries mounted on the right hand side of frame
 24 volt - 60 amp. with built-in IC regulator
 24 volt trailer wiring supplied at rear of cab

CLUTCH

Dry twin plate, hydraulically operated clutch release mechanism with air assistance

Diameter of clutch disc: 400 mm

TRANSMISSION

Make and model: Eaton Fuller, RTLO-18918B
 Eighteen forward speeds and four reverse, with constant mesh and synchromesh on range shift. Mechanical remote control operated shift. Integral oil pump and cooler with 13 litre oil capacity. PTO Openings - top RHS and bottom.

Gear ratios:	(Low)	Gear	(High)	(Low)	Gear	(High)
	14.40	Low	12.29	2.28	5th	1.94
	8.51	1st	7.26	1.62	6th	1.38
	6.05	2nd	5.16	1.17	7th	1.00
	4.38	3rd	3.74	0.86	8th	0.73
	3.20	4th	2.73	15.06	Rev.L	4.03
				12.85	Rev.H	3.43

BRAKES

Full WABCO electronic air brake system (EBS), dual air line system, aluminium air tanks, automatic adjusting, taper roller, internal expanding leading and trailing shoe type with 4 channel ABS and traction control (ASR).

Air pressure:	7.2 - 8.5 kg/cm ²		
	Front	Rear	Total
Drum diameter:	410 mm	410 mm	
Lining area:	2,984 cm ²	7,296 cm ²	10,280 cm ²

Hand operated pneumatically controlled spring park brake acting on both drive axles. Progressive trailer brake hand controller with rear of cab air connections

STEERING

Recirculating ball screw type steering box with hydraulic power assist
 Adjustable, tilt and telescopic type column with steering lock - 460mm steering wheel

Steering gear ratio: 22.42 : 1

WHEELS AND TYRES

Number and size of tyre: Front - single 295 / 80R 22.5 152/148M
 Rear - dual 11 R 22.5 - 16PR 148/145L
 Pressed steel disc type wheel, 1 piece rim, 8.25 x 22.5, offset 165 mm, ISO 10 studs
 One spare wheel and tyre strapped to frame. Carrier (STC) supplied (see Options)

AXLES

FRONT **NISSAN DIESEL FF85**
 Drop forged steel "I" section beam, reverse "ELLIOT" type
Front axle capacity: 8,500 kg *Refer to Load Capacity Summary for max permissible load

REAR **NISSAN DIESEL RM1A**
 Fully floating pressed steel banjo type housing, in-line tandem type power divider with remote operated lock up.
Final reduction gear: Single reduction, hypoid gear
Final reduction gear ratio: 4.625
Rear axle capacity: 23,600 kg *Refer to Load Capacity Summary for max permissible load

SUSPENSION

FRONT
 Long taper leaf spring with anchor at front and shackle at rear

Width x length: 90 x 1,550 mm
The number of leaves: 3
Spring constant: 364 N/mm (37.1 kg/mm)
Shock absorbers: Telescopic double acting

REAR
 Trunnion-mounted semi-elliptic leaf springs with 6 torque rods

Width x length: 90 x 1300 mm
The number of leaves: 8
Spring constant: 2672 N/mm (272.5 kg/mm)

LOAD CAPACITY SUMMARY

	Front (kg)	Rear (kg)
Axle capacity	8500	23600
Steering / Spring Capacity	6000	23600
Tyre capacity	7100	23200
Max capacity (limit kg)*	6000	23200

Note: Based on 295/80R 22.5 front and 11R 22.5 rear tyres and standard springs

GW470 Leaf Suspension

CAB

Forward control, full floating air suspension cab with shock absorbers
 Electric-Hydraulic cab tilt system with 65° tilt
 Front opening inspection bonnet
 3 piece air dam front bumper
 90° opening doors

Standard Equipment

Overhead centre console with driver and passenger sunvisor and overhead tray
 24v Cigarette lighter / power supply + 2 ash trays
 Large centre console
 Large fluorescent interior light
 Driver and passenger On / Off / Door interior lights
 Triple arm, 2-speed wipers with variable intermittent and integrated washers
 Heated and electricly operated LH and RH main mirrors
 Passenger side, rear and downward spot mirrors
 Electric horn, reverse warning light and alarm
 2 occupant seats with retractable seat belts
 Multi adjustable air suspended driver's seat with auto height control
 Flat folding assistant seat with lift up base
 ADR42/04 compliant sleeper bunk with mattress (Suitable for "two up driving")
 Full cab curtain rails with curtains (Covers all windows)
 Power operated driver and passenger windows
 Remote operated keyless central locking
 Fully automatic electronic climate control air conditioning
 Heated / cooled storage box and 2 centre drink holders
 AM/FM radio with CD player
 Tachograph (7day)
 Cruise control - Stalk mounted
 Rear facing work light mounted on rear of cab
 Halogen multi reflector headlamps with remote height adjustment
 Roof mounted clearance lights (ADR49/00)
 2 door cup holders

Standard Equipment *continued*

2 DIN sized compartments for accessory fitment
 Tinted windows

FRAME

Ladder, Channel type chassis construction

Height x width x thickness: 298 x 90 x 7 mm

Material: Pressed carbon steel

Chassis data: Tensile Yield Modulus

Strength: 55kg/mm² 48kg/mm² Refer Body Manual
 UD Trucks website

Turntable angles: Fitted

INSTRUMENTS

Dash design integrates an array of instruments and warning / informational lights
 Individual audible warning tones
 A Drivers Information System displaying useful vehicle data including date / time, oil pressure, voltmeter, trip information along with service intervals for engine, transmission and differentials.

FACTORY OPTIONAL EQUIPMENT (Indent order only)

Paint colours
 4.875 diff ratio
 80Amp alternator with built-in IC regulator
 Heavy duty taper leaf front springs (43.8 kg/mm - 6500kg capacity)
 Front stabilizer bar
 11R 22.5 16PR Front tyres
 Alcoa Aluminium wheels
 400lt chassis mounted aux fuel tank with lockable fuel cap (RHS) - Replaces STC
 Centre seat with seat belt (Replaces centre console)
 Electronic engine governor control
 Electronic transmission PTO control
 Spare tyre fitment (Dealer fit Option)

PERFORMANCE (Calculated)

Max. speed:

Gradeability 1st gear (Calculated):

Gradeability 18th gear (Calculated):

Est. RPM @ 100km/h:

4.625 diff ratio with 11R 22.5 tyres

100km/h (Speed limited - ADR65/00)

38.6% @ 70,000kg

1.0% @ 70,000kg

1773rpm

4.875 diff ratio with 11R 22.5 tyres

100km/h (Speed limited - ADR65/00)

40.8% @ 70,000kg

1.1% @ 70,000kg

1868rpm

GENERAL SPECIFICATIONS (approx.)

Wheel Base	Weight (kg)				
	GVM*	GCM**	FA ¹	RA ¹	Total Tare ¹
H	26000	70000	4545	3605	8150

Dimensions (mm)												
WB	OL	OW	OH ²	FT	RT	ROH	CA	GC ²	FHF ²	FHR ²	Turn Radius Kerb to Kerb	
3950	7185	2490	2990	2040	1840	1810	3100	260	1000	1090	6900	

¹Weight estimated includes fluids (not fuel or AdBlue®) excludes tools, STC and spare wheel. When fitted with factory alloy wheels, subtract 37kgs from front and 148kgs from rear tare weight.

²Based on vehicle with standard steel wheels with 295/80R 22.5 front and 11R 22.5 rear tyres.

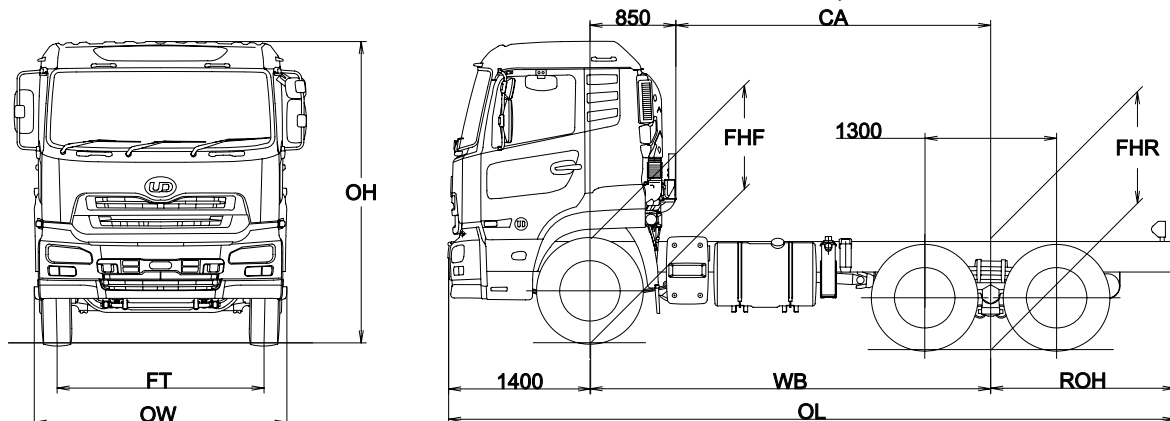

Imported and distributed by Volvo Commercial Vehicles Australia (ABN: 27 000 761 259). Photos for illustration purposes. Volvo Commercial Vehicles Australia reserves the right to modify design and change equipment without previous notification. Please consult with UD Trucks dealer for the latest information about vehicle specification.

*Rated GVM and axle capacities are subject to Federal, State and Territory legal requirements. **Higher GCM on engineering application, see your UD Trucks dealer.

